

Elixo 800 230V RTS

Yana kayar kapılar için motor sistemleri

10 M | 800 KG'A KADAR

Güçlü ve güvenilir

- Kolay kurulum
 - > Yere sabitleme vidalarına üstten kolay erişim
 - > Kurulum yapan kişinin herhangi bir ayar yapması gerekmez
- Güvenilirlik ve sağlamlık
 - > 30 yıllık grup deneyimine dayanan mekanik tasarım
 - > Yavaşlayarak durma
- Kullanımı kolay
 - > İç taraftan anahtarla kolayca manuel açma.



Montaj delikleri

Paketler

						
Elixo 800 230 V RTS Motor	Keygo RTS	Montaj Plakası	Keytis^{MS} 2 RTS	Flaşör Eco Pro 230 V	Fotosel Master Pro Bitech	Palet Başına Paket
	Ref. 1841064	Ref. 9018678	Ref. 1841026	Ref. 9020138	Ref. 1841155	

Standart Paket RTS	•	• 2x	•	-	-	-	36
Ref. 1216454							
Eco Konfor Paketi RTS	•	-	•	• 2x	•	•	36
Ref. 1216455							



Standart kurulum

1. Elixo 800 230 V RTS
2. Flaşör
3. Açık hava anteni

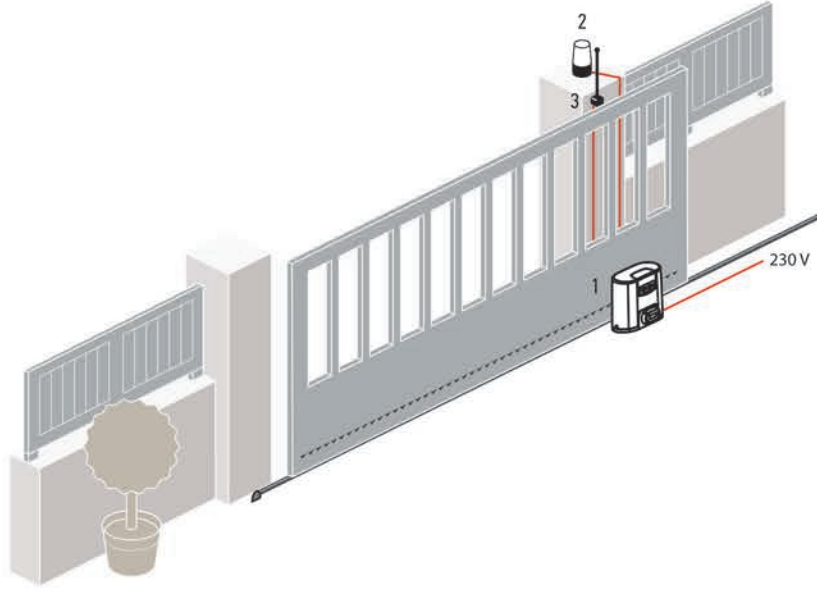

Genel toplam boyut

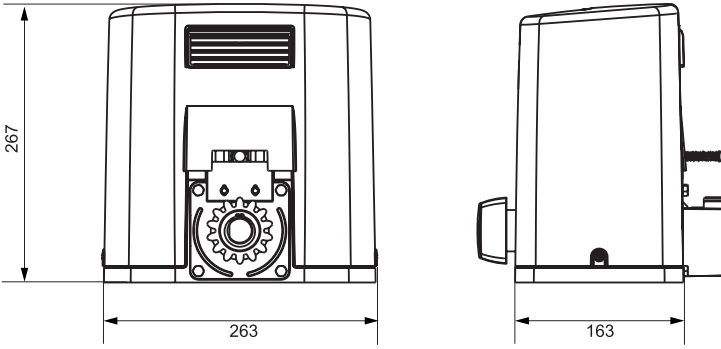

Teknik özellikler

Şebeke güç beslemesi	220 / 240 V - 50 / 60 Hz	RTS radyo frekansı	433.42 MHz
Motor voltajı	230 Vac	Uzaktan kumanda sayısı	128 adet
Maksimum güç tüketimi	300 W	Koruma indeksi	IP 44
Aksesuar güç kaynağı	24 Vac / 360 mA	Çalışma sıcaklığı	-20°C ila +60°C
3 m'ye kadar açılma süresi	21 s		

Özel aksesuarlar



Radio tuş takımı metal 1 TRS

Ref. 1841111 (Fransa)

Ref. 1841116 (Uluslararası)



1 metrelik çelik ray

Ref. 9011069



Darbe emici kauçuk şerit

Ref. 9019613



Alıcılı emniyet kiti

Ref. 9019611